

CUSTOMER NAME
PHONE #
FAX #
MAKE
MODEL
YEAR
BOLT PATTERN
FENDER HEIGHT
FACTORY WHEEL SIZE
FACTORY TIRE SIZE
A MOUNTING SURFACE TO FIRST OBSTRUCTION FRAME SIDE
B MOUNTING SURFACE TO INSIDE FENDER
C HUB DIAMETER
D BRAKE DIAMETER: CENTER TO TOP OF CALIPER (x2)
E PROTRUSION OF CALIPER PAST MOUNTING SURFACE
F HUB LENGTH

### FRONT WHEEL SECTION THROUGH FENDERWELL DISC BRAKES

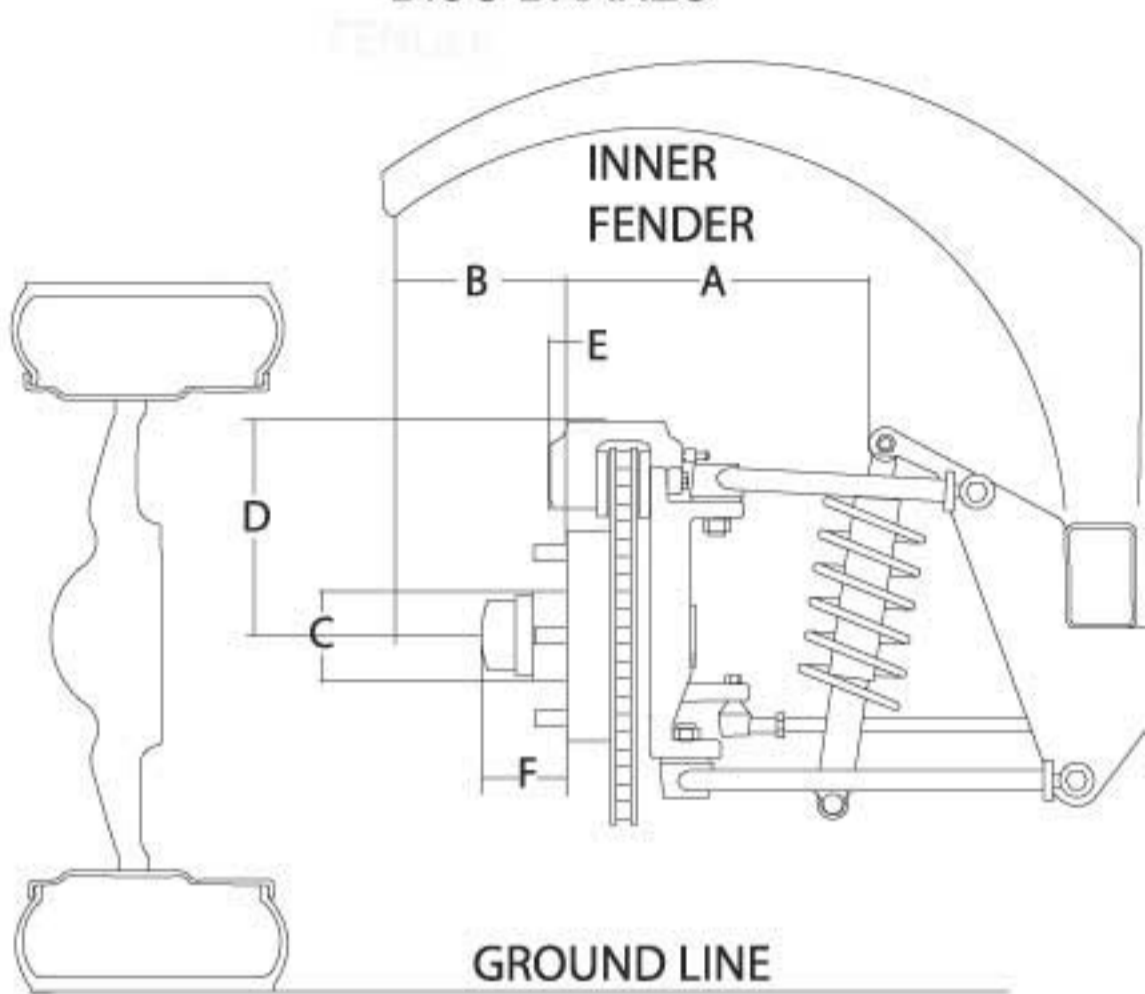

CUSTOMER NAME
PHONE #
FAX #
MAKE
MODEL
YEAR
BOLT PATTERN
FENDER HEIGHT
FACTORY WHEEL SIZE
FACTORY TIRE SIZE
A MOUNTING SURFACE TO FIRST OBSTRUCTION FRAME SIDE
B MOUNTING SURFACE TO INSIDE FENDER
C DRUM DIAMETER

### REAR WHEEL SECTION THROUGH FENDERWELL DRUM BRAKES

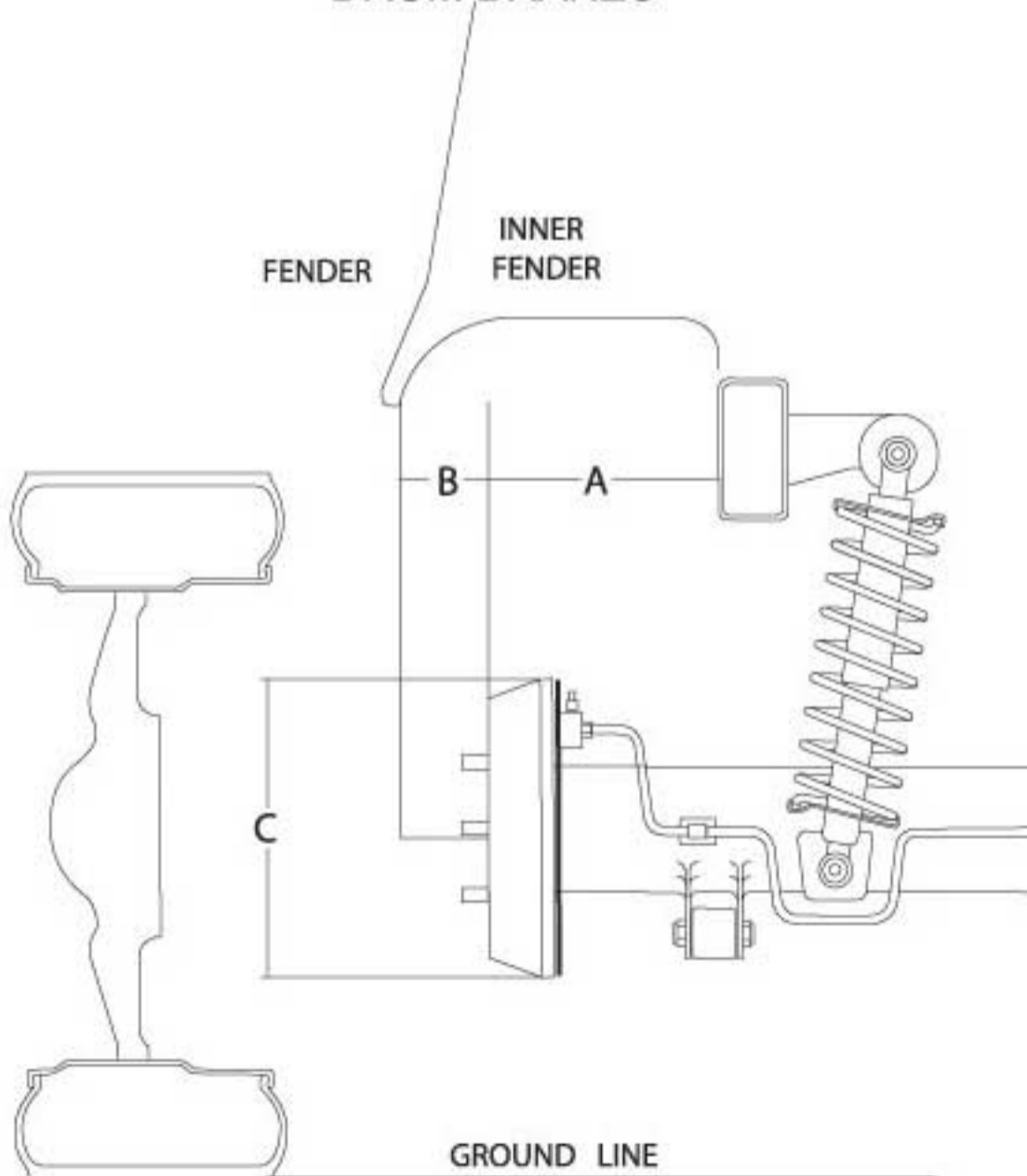

wheels with a nostalgic feel

Our Fax # 1-423-899-8473  
 Our Phone # 1-800-281-2819  
 Local & International 1-423-899-0227